

Flanged Extended Inner Ring Bearings

Inch series for shaft sizes from 0.0469" to 0.3125"

Chrome steel and stainless steel

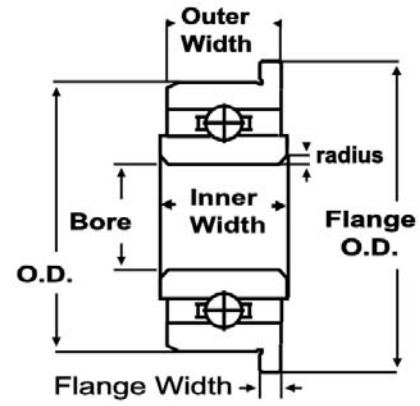

This series have an inner ring that is wider than the outer ring by 0.0312" (0.0156" on each side) and a flange on the outer ring for locating the bearing in a housing. Usually supplied in KS440 (ACD34/X65Cr13) stainless steel, these can withstand heavy radial loads and moderate thrust loads in both directions.

| Bore | O.D. | Flange O.D. | r.min. | Open Bearing | | | | Shielded Bearing | | | |
|---|--------|-------------|--------|--------------|-------------|--------------|---------|------------------|-------------|--------------|-----------|
| | | | | Outer Width | Inner Width | Flange Width | SMB Ref | Outer Width | Inner Width | Flange Width | SMB Ref. |
| <p><i>Dimensions in inches except radius. Load and speed ratings are the same as for Inch Miniature Bearings</i> <i>Sizes marked * are also available with rubber seals.</i></p> | | | | | | | | | | | |
| 0.0469 | 0.1562 | 0.203 | 0.1 | 0.0625 | 0.0937 | 0.013 | FRW0 | 0.0937 | 0.125 | 0.031 | FRW0ZZ |
| 0.055 | 0.1875 | 0.234 | 0.1 | 0.0781 | 0.1094 | 0.023 | FRW1 | 0.1094 | 0.1406 | 0.031 | FRW1ZZ |
| 0.0781 | 0.25 | 0.296 | 0.1 | 0.0937 | 0.125 | 0.023 | FRW1-4 | 0.1406 | 0.1719 | 0.031 | FRW1-4ZZ |
| 0.0937 | 0.1875 | 0.234 | 0.1 | 0.0625 | 0.0937 | 0.018 | FRW133 | 0.0937 | 0.125 | 0.031 | FRW133ZZ |
| | 0.3125 | 0.359 | 0.15 | 0.1094 | 0.1406 | 0.023 | FRW1-5 | 0.1406 | 0.1719 | 0.031 | FRW1-5ZZ |
| 0.125 | 0.25 | 0.256 | 0.1 | 0.0937 | 0.125 | 0.023 | FRW144 | 0.1094 | 0.1406 | 0.031 | FRW144ZZ |
| | 0.3125 | 0.359 | 0.1 | 0.1094 | 0.1406 | 0.023 | FRW2-5 | 0.1406 | 0.1719 | 0.031 | FRW2-5ZZ |
| | 0.375 | 0.422 | 0.15 | 0.1094 | 0.1406 | 0.023 | FRW2-6 | 0.1406 | 0.1719 | 0.031 | FRW2-6ZZ |
| | 0.375 | 0.44 | 0.3 | 0.1562 | 0.1875 | 0.03 | FRW2 | 0.1562 | 0.1875 | 0.03 | FRW2ZZ * |
| 0.1562 | 0.3125 | 0.359 | 0.1 | 0.1094 | 0.1406 | 0.023 | FRW155 | 0.125 | 0.1562 | 0.036 | FRW155ZZ |
| 0.1875 | 0.3125 | 0.359 | 0.1 | 0.1094 | 0.1406 | 0.023 | FRW156 | 0.125 | 0.1562 | 0.036 | FRW156ZZ |
| | 0.375 | 0.422 | 0.1 | 0.125 | 0.1562 | 0.023 | FRW166 | 0.125 | 0.1562 | 0.031 | FRW166ZZ |
| | 0.5 | 0.565 | 0.3 | 0.1562 | 0.1875 | 0.042 | FRW3 | 0.196 | 0.2273 | 0.042 | FRW3ZZ * |
| 0.25 | 0.375 | 0.422 | 0.1 | 0.125 | 0.1562 | 0.023 | FRW168 | 0.125 | 0.1562 | 0.035 | FRW168ZZ |
| | 0.5 | 0.547 | 0.15 | 0.125 | 0.1562 | 0.023 | FRW188 | 0.1875 | 0.2188 | 0.045 | FRW188ZZ |
| | 0.625 | 0.69 | 0.3 | 0.196 | 0.2273 | 0.042 | FRW4 | 0.196 | 0.2273 | 0.042 | FRW4ZZ * |
| 0.3125 | 0.5 | 0.547 | 0.15 | 0.1562 | 0.1875 | 0.031 | FRW1810 | 0.1562 | 0.1875 | 0.031 | FRW1810ZZ |